

DIRECTIONS FOR CLEAR VIEW FILTRATION CHEVY BLOCK ADAPTER KIT PART# 200

THE CHEVY BLOCK ADAPTERS ARE DIRECTIONAL, THERE IS AN ARROW ENGRAVED INTO THE BLOCK ADAPTER THAT MUST POINT TO THE FRONT OF THE ENGINE. **THIS IS VERY IMPORTANT, IF INSTALLED WRONG IT COULD RESTRICT THE OIL FLOW AND DAMAGE THE ENGINE !!!** THE INLET AND OUTLET OPENINGS ARE ENGRAVED IN AND OUT. TO HOOK UP THE OIL LINES CORRECTLY, THE OUT OR OUTLET OPENING NEEDS TO BE HOOKED TO THE IN OR INLET OPENING OF THE REMOTE FILTER. THEN HOOK THE OUT OR OUTLET OF THE REMOTE FILTER TO THE IN OR INLET OPENING OF THE BLOCK ADAPTER.

LOOK UP THE DISPOSABLE FILTER FOR APPLICATION TO MAKE SURE THE THREAD SIZE MATCHES THE ADAPTER.

HI-FLOW OUTLET PORT
1-1/16" - 12TPI THREAD
USES #12 O-RING
BOSS FITTING

**ARROW NEEDS TO POINT
TO THE FRONT OF THE
ENGINE WHEN INSTALLED**

**HI-FLOW
OUTLET PORT**

**HI-FLOW
INLET PORT**

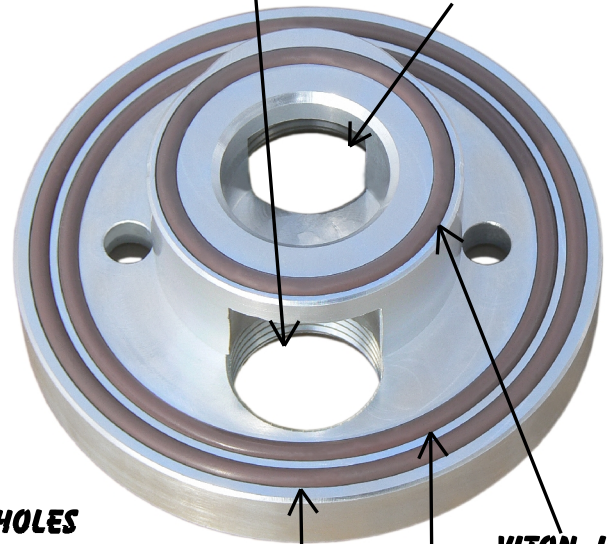
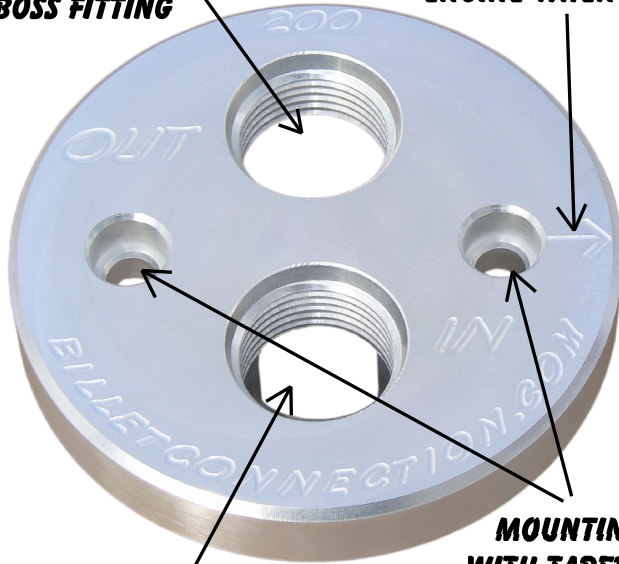

HI-FLOW INLET PORT
1-1/16" - 12TPI THREAD
USES #12 O-RING
BOSS FITTING

**MOUNTING BOLT HOLES
WITH TAPERED O-RING SEAT**

**VITON® OUTER
O-RING
SEAL # 238**

**VITON® INSIDE
O-RING SEAL # 223**
**VITON® OUTER
O-RING
SEAL # 235**

MOUNTING BOLTS

2 - 5/16" X 1-1/2" LONG ALLEN HEAD

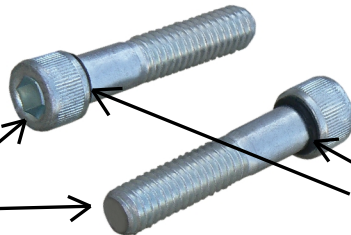

THE ALLEN HEAD BOLTS SUPPLIED HAVE SMALL SEALING O-RINGS INSTALLED ON THE BOLTS. **MAKE SURE TO PUT A LITTLE OIL OR GREASE AROUND THE O-RING BEFORE INSTALLING AND TIGHTENING THE BOLTS.** IF THE O-RINGS NEED REPLACED, THEY ARE SIZE 1MM BY 8MM O-RINGS. TO MAKE IT EASY TO INSTALL NEW O-RINGS ONTO THE BOLTS. TAPE THE THREADS WITH MASKING TAPE AND THE O-RINGS WILL SLIDE RIGHT ON. IF YOU DO NOT TAPE THE THREADS IT WILL NOT BE EASY TO PUT THE O-RINGS ON AND MAY DAMAGING THEM.

THE BLOCK ADAPTERS INLET AND OUTLET OPENINGS ARE THREADED TO 1 1/16" - 12 THREADS PER INCH, THIS THREAD USES A FITTING CALLED A #12 O-RING BOSS ON THE END THAT THREADS INTO THE BLOCK ADAPTER, THE OTHER END COMES IN DIFFERENT STYLES OF FITTINGS. **THE RECOMMENDED FITTING FOR THE CHEVY BLOCK ADAPTER IS A #12 O-RING BOSS TO A #12 JIC MALE FITTING.**

THIS FITTING HAS THE SAME INSIDE DIAMETER THAT A CHEVY ENGINE HAS FOR THE OIL INLET AND OUTLET PASSAGES. THIS FITTING WILL NOT RESTRICT OIL FLOW.

REPLACEMENT O-RING KIT AVAILABLE FOR CHEVY BLOCK ADAPTERS. O-RING KIT PART # 201 CONSISTS OF THREE O-RINGS FOR BLOCK ADAPTER AND TWO O-RINGS FOR MOUNTING BOLTS.

CLEAR VIEW FILTRATION ALSO CARRIES FITTINGS, O-RINGS KITS AND FASTENERS NEEDED FOR THE CHEVY BLOCK ADAPTERS. CHECK OUT OUR WEBSITE AT CLEARVIEWFILTRATION.COM FOR MORE PRODUCTS AND INFORMATION.