

CLEAR VIEW FILTRATION 6" HI-FLOW FILTER DIRECTIONS

MORE PRODUCTS & INFORMATION AT: WWW.CLEARVIEWFILTRATION.COM

CLEAR VIEW FILTRATION'S PATENTED SEE THROUGH FILTER ASSEMBLY ALLOWS THE USER TO VISUALLY SEE THE FLUID PUMPING THROUGH THE FILTER WHICH HELPS DETERMINING THE CONDITION OF THE FLUID. WHEN FLUID IS NOT BEING PUMPED THROUGH THE FILTER, IT CAN BE QUICKLY DRAINED USING COMPRESSED AIR, EXPOSING THE FILTER ELEMENT AND ANY PARTICLES FILTERED OUT OF THE OIL SYSTEM. EVEN WHEN FILTERING NON TRANSPARENT FLUID LIKE ENGINE OIL. VISUAL INSPECTION OF THE FILTERED PARTICLES HELPS THE USER TO DETERMINE IF THE CONTAMINANTS AND PARTICLES ARE FROM NORMAL USE OR FROM PARTS EXCESSIVELY WEARING IN MACHINERY OR IN THE ENGINE SUPPLYING THE FILTER ASSEMBLY. ENGINE OR MACHINERY INSPECTION DONE IN SECONDS AND WITHOUT DRAINING OR LEAKING ANY FLUID OR OIL, UNBOLTING OR LOOSENING ANY FASTENERS OR FITTINGS AND WITHOUT THE LOSS OF FLUID OR OIL OUT OF THE SYSTEM, WHICH SAVES USERS AND BUSINESS'S TIME AND MONEY!

SEE THROUGH OIL FILTERS ARE RATED FOR 150 PSI MAXIMUM PRESSURE AT A MAX FAHRENHEIT TEMP OF 200 DEGREES

6" HI-FLOW FILTER ASSEMBLY

PART #100-60

PART #100-115

PART #100-60-B

PART #100-115-B

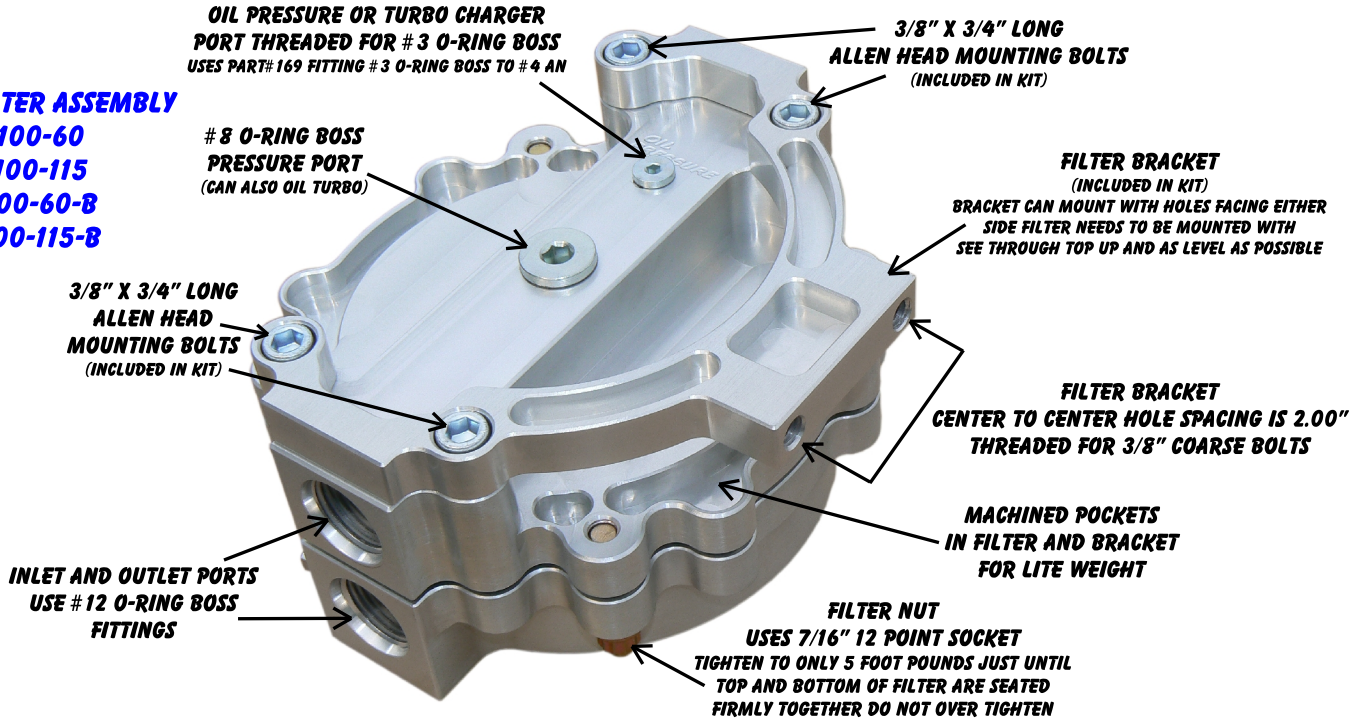

FILTER NUTS AND BRACKET ALLEN BOLTS NEED TO BE TIGHTENED BEFORE FILTER IS RAN USE BLUE LOG TIGHT ON BRACKET MOUNTING BOLTS AND ANTI-SEIZE OR OIL ON FILTER NUTS. THE FILTER ELEMENT SEALS NEED TO BE PRE-OILED BEFORE TIGHTENING THE FILTER TOP

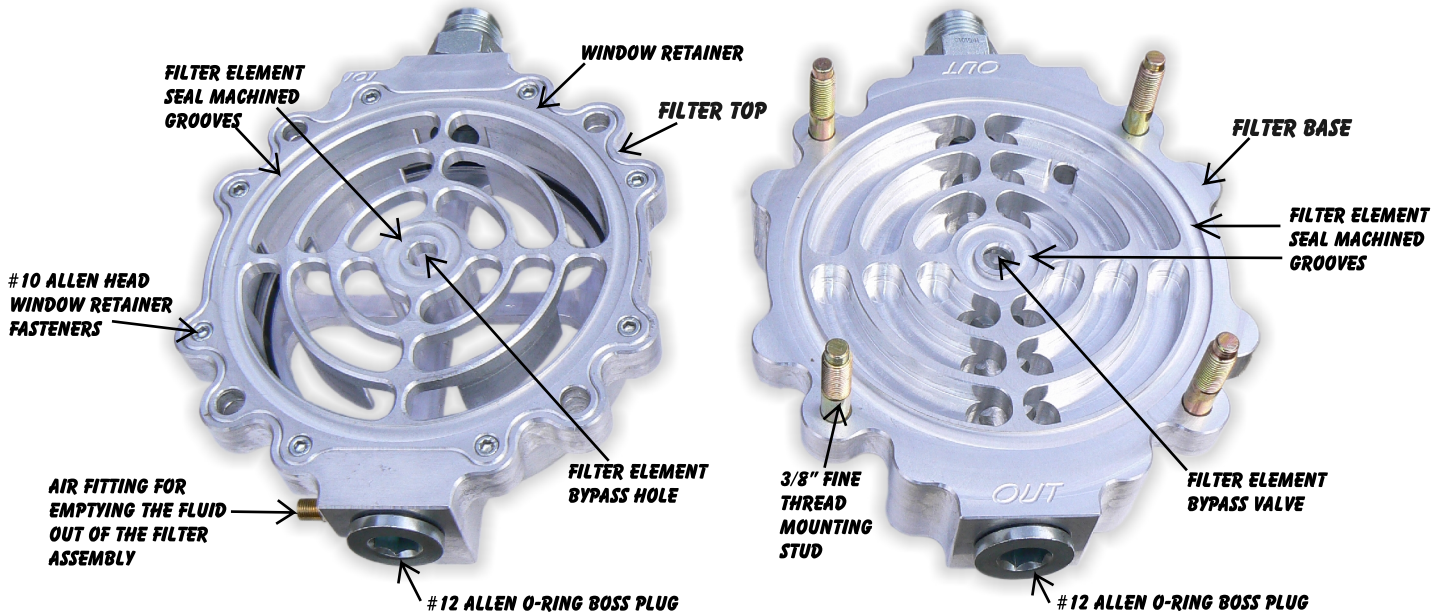

CLEAR VIEW FILTRATION'S GUARANTEE (IMPORTANT!! READ BEFORE INSTALLING) THIS OIL FILTER IS GUARANTEED 90 DAYS FROM DATE OF PURCHASE TO BE FREE FROM DEFECTS IN MATERIALS AND WORKMANSHIP. WE SHALL IN NO EVENT BE LIABLE FOR DEATH, INJURIES, OR DAMAGES TO PERSONS OR PROPERTY ARISING FROM THE USE OF THIS PRODUCT. THIS INCLUDES DOWN TIME, LOSS OF USE OF THE PRODUCT, MACHINERY, OR VEHICLE. ALSO TOWING, RENTING OR BUYING A VEHICLE DURING DOWN TIME. IF THERE IS EVER A PROBLEM WITH THE FILTER ASSEMBLY, THE FILTER MUST BE SENT BACK TO CLEAR VIEW FILTRATION FOR ALL WARRANTIES OR GUARANTEE IS VOID. WE SHALL NOT BE LIABLE FOR SHIPPING COSTS OF THE FILTER ASSEMBLY, OR LABOR COSTS TO UNHOOK OR REINSTALL THE FILTER ASSEMBLY. IF THE FILTER ASSEMBLY IS INSTALLED THE PURCHASER AND OR USER OF THE PRODUCT IS AGREEING TO THE TERMS ABOVE. IF THE PURCHASER AND OR USER OF THE PRODUCT DOES NOT AGREE TO THE TERMS ABOVE, AND THE FILTER ASSEMBLY WAS NOT DAMAGED, SCRATCHED, OR INSTALLED THEN CONTACT US AT CLEAR VIEW FILTRATION AND SEND THE FILTER ASSEMBLY BACK AND WE WILL GIVE THE PURCHASER A FULL REFUND.